

MO-300 Moulder



Glimek MO-300 is the true Scandinavian origin of moulder, dedicated for all types of dough handling. Loaves, baguettes, buns or even round bread/pizzas can be moulded. Foldable pressure board for easy cleaning.

SDG



Sveba Dahlen Group

SVEBA
DAHLÉN



Glimek
baking system

Scandinavian know-how – worldwide

MO-300 Moulder



Centrally adjustable infeed enables a correct positioning of the dough piece

Two pair of 400 mm wide adjustable pressure rollers with spring loaded scrapers for easy cleaning

Parallel adjustable side guides for an efficient positioning (option)



Pressure board 650 x 1100 mm is foldable and can be locked in an upright position for easy cleaning



Collection tray with two positions enables straight line outfeed

Accessories

Parallel adjustable side guides	Turnable handles for parallel adjustment of the side guides
Lower side guides 10 mm	Non stick coated side guides 10 mm, standard is 20 mm, recommended for low weight ranges
Motorized pressure board	Counterrotating motorized pressure board with fixed speed in order to prolonging the moulding length
Pressure board customized	Special customized pressure board can be offered on request
Special belt	Special customized belt can be offered on request
Three knives in pressure board for 4-pieces	Cut the dough piece into 4 pieces. Standard distance between the knives = 100 mm
Dividing unit for minibaguettes	Divides a baguette into 3 mini baguettes

Technical data

Capacity range	up to 3000 dough pieces/hour*
Weight range	30-1800 grams
Working width	up to 650 mm
Power supply	1,1 kW
Weight, net	550 kg
Weight, gross (carton + pallet)	610 kg
Volume, gross	2,15 x 1,00 x 1,92 = 4,13 m ³

* Depending on weight and consistency of dough piece

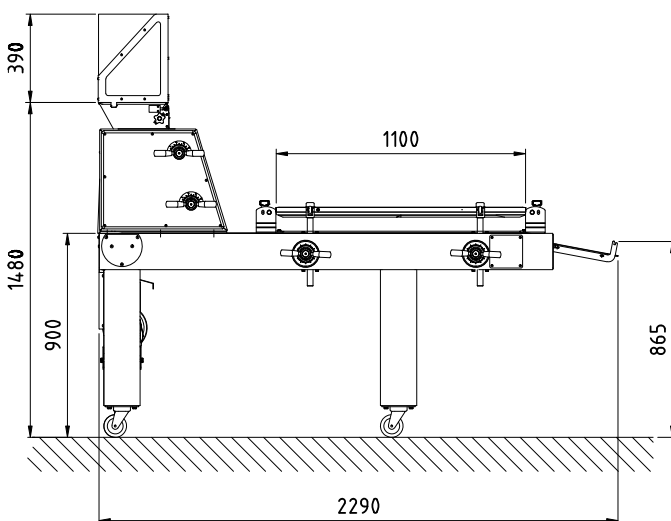

Handles on left (L) or right (R) side, please specify on the order

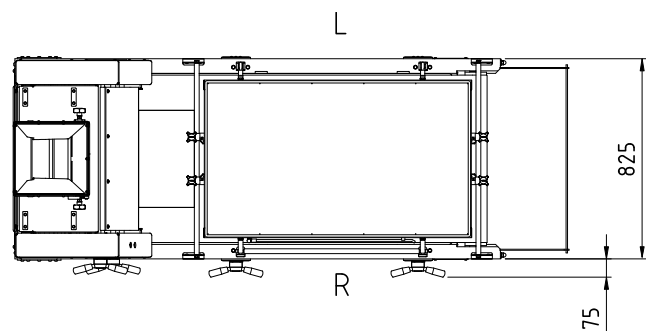

Glimek AB

P.O. Box 124 • S-280 64 GLIMÅKRA • Sweden
 Phone +46 44 449 00 • Fax +46 44 449 10
 e-mail: office@glimek.se • www.glimek.se