

Humidifiers EB/EBK



Available in electrically heated models.

The unique technology in a Revent prover/retarder will take your baking quality to an even higher level.

Revent[™]
More than Quality.

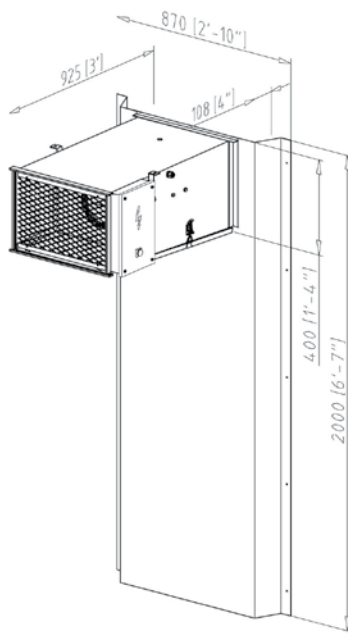

HUMIDIFIER EB-10*

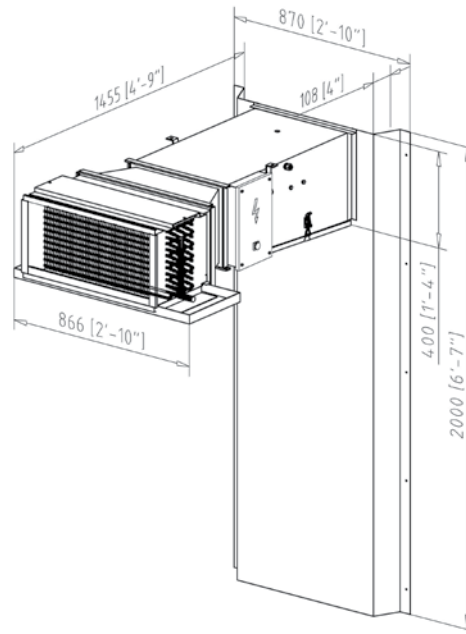

HUMIDIFIER EBK-10*

	EB-10					EBK-10				
Units	1	2	3	4	6	1	2	3	4	6
Heating	Electric									
Heating Capacity, kW	10	20	30	40	60	10	20	30	40	60
Cooling Capacity, kW						2,6	5,2	7,8	10,4	15,6
Cooling Capacity, BTU						8800	17600	26400	35200	52800
Electric Connection, kW	10,2	20,4	30,6	40,8	61,2	10,2	20,4	30,6	40,8	61,2
Proving Capacity, m ²	0-6	6-12	12-18	18-24	24-36	0-6	6-12	12-18	18-24	30-36
Proving Capacity, sqf	0-65	65-130	130-195	195-260	260-390	0-65	65-130	130-195	195-260	260-390

Continuous product development is a Revent policy. Therefore, we reserve the right to change specifications and/or design without prior notice. Pictures or drawings may include product options.

EB/EBK with Revent Air Wash

Revent Air Wash is one of the most sophisticated humidification system on the market – yet easy to use and maintain. The heavy duty system is broadly used in large wholesale bakeries around the world.

Humidifier EB-10

This humidifier is equipped with elements with a heating capacity of 10 kW. The maximum heating capacity for one unit is 65 square feet/6m². Up to 6 EB-10 units can be connected to 1 control unit.

Humidifier EBK-10

This unit is for combined retarding/proofing rooms. The difference compared to EB-10, is that the humidifier has been equipped with a cooling coil unit on the inlet side. A suitable compressor has to be obtained locally – not supplied by Revent - as well as expansion valve, filter, pressostat, solenoid valve, inspection glass and tube. These components have to be installed by a local refrigerator engineer.

Revent sales representative:



Revent International AB

PO Box 714, SE 194 27 Upplands Väsby, Sweden
Phone +46 8 590 006 00, fax +46 8 590 942 10
E-mail info@revent.se, www.revent.com