

# SD-600 Dough Divider

Patent  
Pending



Glimex SD-600 is a stainless steel, volumetric dough divider available in both a 3 chamber and 2/4 chamber execution. The machine comes as standard equipped with stepless adjustable pneumatics for very gentle dough handling ranging from stiff to soft dough. Another standard feature is our user friendly touch screen for setting and storing recipes. The SD-600 has a robust chassis designed for high industrial production. During product development much emphasis has been put on hygiene and reliability.

# SD-600 Dough Divider

A 22 litre oil tank equipped with level detectors. First level: acoustic signal warning. Second level: acoustic signal with machine stop.



Stepless adjustable pneumatic system for very gentle handling of different types of dough. Can be adjusted during production.



Intuitive and user-friendly touch screen, including storage of recipes and countdown of the batch size in both quantity and time. Selected sections of the user manual and service reports can be viewed as well.



Quick release on outfeed conveyor to facilitate cleaning.

## Accessories

Hopper 225 litre	Dough Hopper 225 lit, approximately 150 kg dough (Standard is 100 lit 70 kg dough)
Flour duster, mechanical	Flour duster on the first conveyor, mechanical
Non-stick coating of hopper 100L	Interior of the dough hopper 100L non-stick to assure a smooth infeed of the dough
Non-stick coating of hopper 225L	Interior of the dough hopper 225L non-stick to assure a smooth infeed of the dough
Hopper lubrication for 225 litre hopper	Automatic lubrication inside the dough hopper, by means of a spread tube system
Special belt	Special customized belt on one or both conveyors

## Technical data

Capacity range	
2-pocket	1000 - 3000 dough pieces/hour
3-pocket	1500 - 4500 dough pieces/hour
4-pocket	2000 - 6000 dough pieces/hour
Weight range	
2-pocket	250 - 1700 gram
3-pocket	150 - 1000 gram
4-pocket	100 - 700 gram
Power supply	2,2 kW
Weight, net	approx 1100 kg
Weight, gross (carton+pallet)	approx 1175 kg

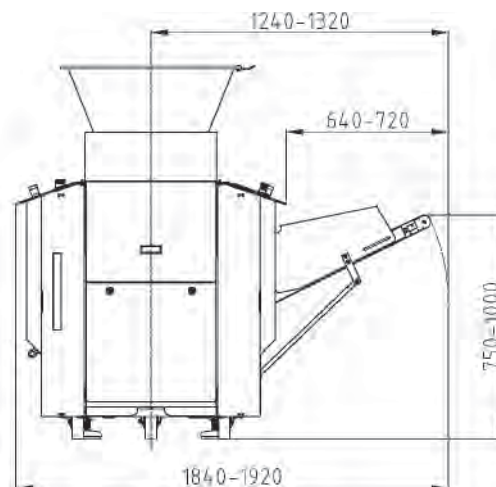
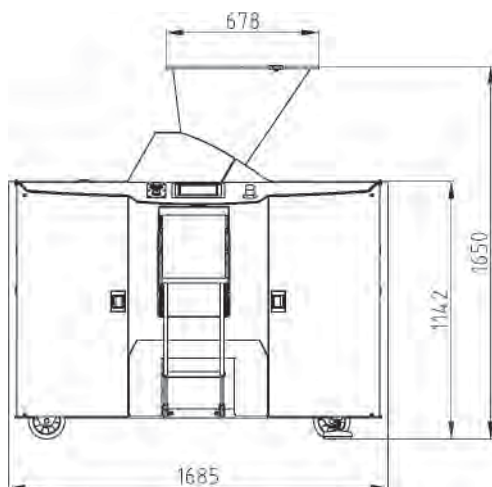

## Glimex AB

P.O. Box 124 • S-280 64 GLIMÅKRA • Sweden  
 Phone +46 44 449 00 • Fax +46 44 449 10  
 e-mail: office@glimex.se • www.glimex.se